

**NEU800 series**

Upright vacuum cleaner; household type

# Owner's Guide

Thank you for purchasing your new Eureka vacuum!

## Important instructions

For easy assembly, please take a few moments to read this owner's guide.

If you have questions about your new vacuum, please contact our customer service **HELPLINE** at 1-800-282-2886. We're here to help!



[www.eureka.com](http://www.eureka.com)

# eureka

# Where to find important vacuum information

## Keep this information

Write the model, type and serial number here:

Date of purchase (keep your receipt) \_\_\_\_\_

Model number and type \_\_\_\_\_

Serial number \_\_\_\_\_

Find these numbers on a label on the bottom of the vacuum cleaner. Refer to these numbers when ordering parts and accessories, or if service is needed.



## This Owner's Guide provides important instructions to prolong the life of your Eureka vacuum cleaner.

**Registration:** To register your product use your smartphone to scan the QR code that will take you directly to the product registration page or visit [www.eureka.com](http://www.eureka.com) and click on the 'Register Your Product' link in the top right corner.

**Inspection:** Carefully unpack and inspect your new Eureka vacuum cleaner for shipping damage. Each unit is tested and thoroughly inspected before shipping. For instructions regarding any shipping damage, call Eureka Customer Service **HELPLINE** at **1-800-282-2886** immediately.

### Contents

|  |       |
|--|-------|
| Important safeguards . . . . .                         | 3     |
| What comes in the carton . . . . .                     | 4     |
| How to identify parts of your vacuum cleaner . . . . . | 5     |
| How to assemble your vacuum cleaner . . . . .          | 6     |
| How to use your vacuum cleaner . . . . .               | 7     |
| How to use accessories . . . . .                       | 8-9   |
| How to maintain dust cup and filters . . . . .         | 10-11 |
| How to maintain the brushroll . . . . .                | 12    |
| How to clean a blockage . . . . .                      | 13    |
| Problem solving . . . . .                              | 14    |
| Trouble shooting . . . . .                             | 14    |
| The Eureka limited warranty . . . . .                  | 15    |
| How to order replacement parts . . . . .               | 16    |

 Follow caution information wherever you see this symbol.

# IMPORTANT SAFEGUARDS

When using an electrical appliance, basic precautions should always be followed, including the following:

## READ ALL INSTRUCTIONS BEFORE USING THIS VACUUM CLEANER

### WARNING



- For the first operation, it is advisable to read the manual carefully before hand and keep it properly for future use.
- Before the first operation, make sure the dust cup or the dust bag is properly installed.
- Only use the vacuum cleaner indoors on dry surfaces and keep the area your cleaning well.
- Do not use without dust bag and/or filters in place.
- Do not leave appliance when plugged in. Unplug from outlet when not in use and before servicing.
- Use only as described in this manual. Use only manufacturer's recommended attachments.
- Don't use this vacuum cleaner if it has been dropped, damaged or left outdoors.
- Don't run over the power cord or use vacuum cleaner if the power cord or plug is damaged. Please contact the Eureka Customer Service HELPLINE at 1-800-282-2886.
- Don't handle the plug or use the vacuum cleaner with wet hands.
- Don't pull or carry this vacuum cleaner by the power cord. Don't use the Power cord as a handle, pull the power cord around corners, sharp edges or close a door over the Power cord. Don't unplug vacuum cleaner by pulling on the power cord.
- Do not unplug by pulling on cord. To unplug, grasp the plug, not the cord.
- Don't vacuum up any flammable or combustible materials (lighter fluid, petrol, kerosene etc.) or use the vacuum cleaner in an area with explosive vapours or liquid.
- Don't vacuum up hot coals, cigarette butts, matches or smoking hot burning items or use in an area where there may be harmful fluids (chlorine, bleach, and ammonia drain cleaner).
- Don't attempt to remove blockages with sharp objects as this may cause damage to your vacuum cleaner.
- Keep hair, loose clothing, fingers, and all parts of body away from openings and moving parts.
- Turn off all controls before unplugging.
- Use extra care when cleaning on stairs.
- Don't use the vacuum cleaner with incorrect voltage as this may result in damage or injury to the user. The correct voltage is listed on the ratings label.
- If abnormal noise, smell, smoke or any other failure or breakage is found during the operation, you should turn off the switch and unplug it. Then contact with your service center for repair. Do not repair by yourself.
- If the supply cord is damaged, it must be replaced by the manufacturer or its service agent or a similarly qualified person in order to avoid a hazard.
- This appliance is not intended for use by persons (including children) with reduced physical, sensory or mental capabilities, or lack of experience and knowledge, unless they have been given supervision or instruction concerning use of the appliance by a person responsible for their safety.
- Children should be supervised to ensure that they do not play with the appliance.
- The plug must be removed from the power socket before any maintenance or replacement.
- Do not put any object into openings. Do not use with any opening blocked; keep free of dust, lint, hair, and anything that may reduce airflow.
- Always turn off this appliance before connecting or disconnecting motorized nozzle.
- The hose contains electrical wires. Do not use when damaged, cut, or punctured. Avoid picking up sharp objects.
- Always turn off this appliance before connecting or disconnecting either hose or motorized nozzle.
- To reduce the risk of electric shock, this appliance has a polarized plug (one blade is wider than the other). This plug will fit in a polarized outlet only one way. If the plug does not fit fully in the outlet, reverse the plug. If it still does not fit, contact a qualified electrician to install the proper outlet. Do not change the plug in any way.

## SAVE THESE INSTRUCTIONS

To reduce the risk of electric shock, this appliance has a polarized plug (one blade is wider than the other).

This plug will fit in a polarized outlet only one way. If the plug does not fit fully into the outlet, reverse the plug.

If it still does not fit, contact a qualified electrician to install the proper outlet. Do not change the plug in any way.



### Motor

**Do Not Oil** the motor or the brush roll at any time. The bearings are permanently lubricated and sealed.

# What comes in the carton

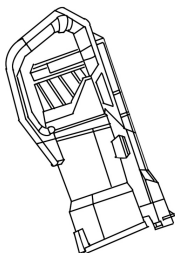

Vacuum canister assembly

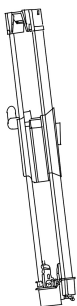

Pole assembly

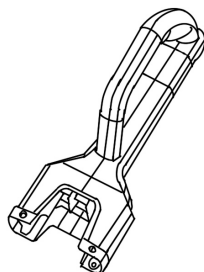

Handle assembly

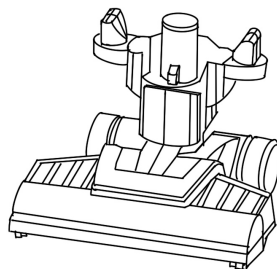

Floor nozzle assembly

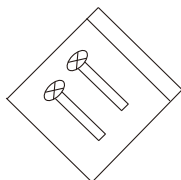

2\* Screws  
(for attaching  
handle to pole)

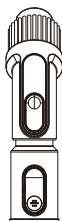

2-in-1 Dusting  
brush + upholstery tool



Crevice tool



Important  
safeguards

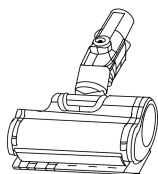

Motorized pet & stair tool  
(Included with some models,  
can be purchased separately)

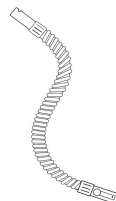

Hose

# How to identify parts of your vacuum cleaner



# How to assemble your vacuum cleaner

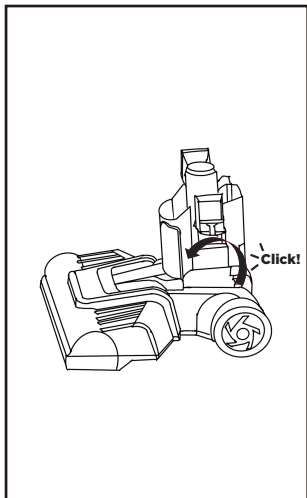

Set floor nozzle assembly on the ground and pull connector joint into upright position until you hear a click.

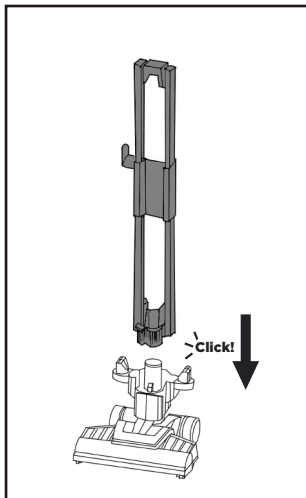

Insert the pole assembly into the opening at the top of the floor nozzle and push down until it clicks into place.

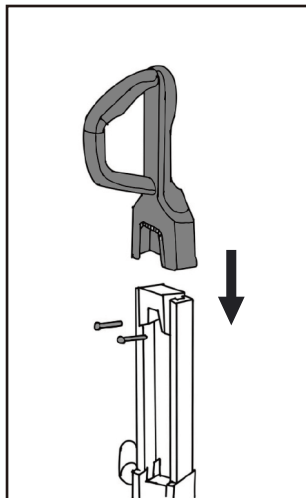

Slide the handle onto the top of the pole assembly and using a screw driver (not included) secure the two screws into place. **Note:** Screws are in small plastic bag attached to the pole.

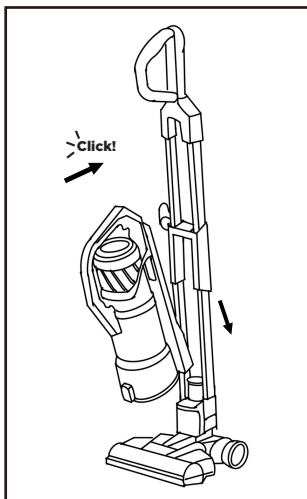

Angle the canister forward and insert bottom of canister onto the yellow floor nozzle connector and then push canister back onto the pole until it clicks in place.

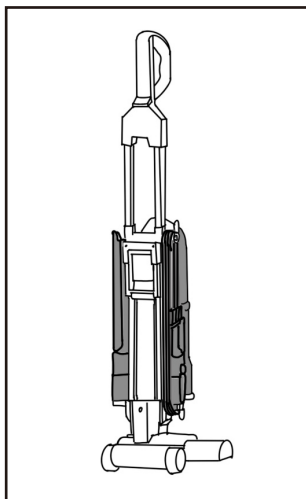

Store crevice tool and 2-in-1 dusting brush on the posts.

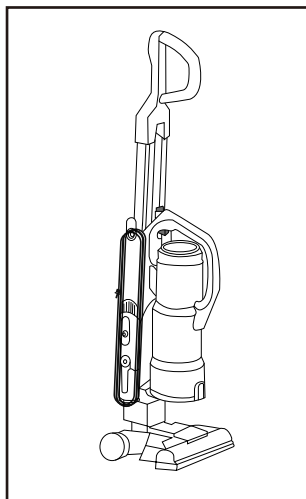

Wrap the cord around the upper and lower cord hooks.

# How to use your vacuum cleaner



## CAUTION

Never operate vacuum cleaner without all filters, filter screen, hose and dust cup in proper position.

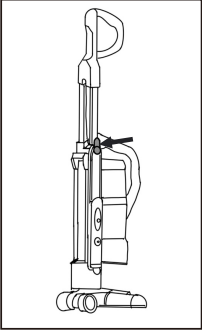

Turn upper cord wrap hook downward to quickly release the cord. Plug power cord into outlet.

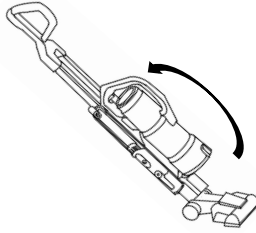

Step on floor nozzle and recline vacuum for vacuuming floors.

**Note:** Brushroll will only spin when vacuum is reclined.

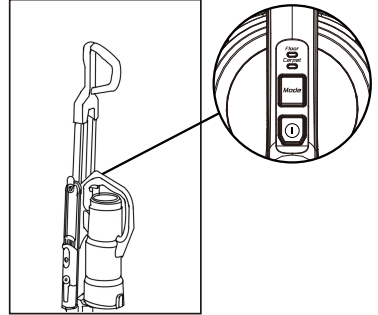

Press **Power** button to turn vacuum on. Press **Mode** button to choose between **Carpet** or for hard floors choose **Floor**. Light above the flooring type will illuminate when that mode is selected.

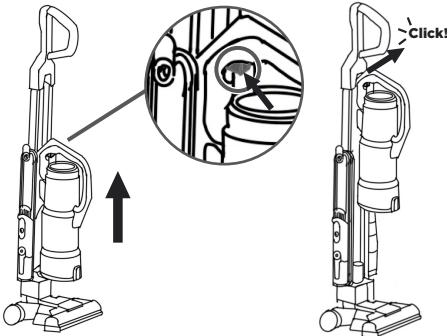

The canister can slide up the pole to clean under furniture. To slide the canister up the pole press the yellow slide up/down trigger button located under the handle and then slide the canister all the way to top of pole until it clicks into place. To lower canister, press the yellow slide up/down trigger button and slide down pole until it clicks into place.

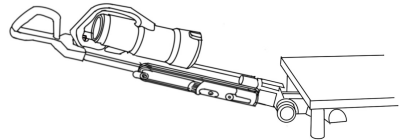

Using as stick mode to clean under furniture places.

# How to use accessories



## CAUTION

When using tools, always place vacuum in upright position. Make sure vacuum cleaner is turned off while attaching tools.

### Using accessories with canister only

- Press and hold the purple canister release button and pull canister away from the pole. (Fig.1)

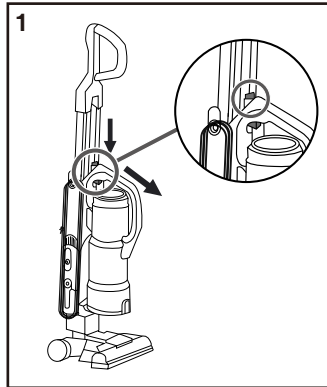

- Insert tools directly into the bottom of the canister assembly until you hear them click into place. (Fig. 2)

**Note:** The motorized pet & stair tool only works when connected directly to the bottom of the canister assembly.

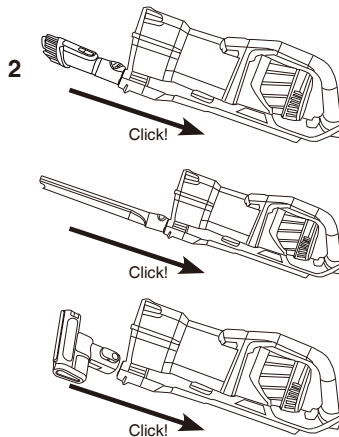

### Using accessories with hose as extension

- Insert one end of hose into the bottom of the canister assembly until you hear it click into place.

- Insert tools directly into the opposite end of the hose until you hear them click into place.

- When finished using accessories, remove by pressing the silver button on the accessory and pulling it away from the hose or the canister assembly.

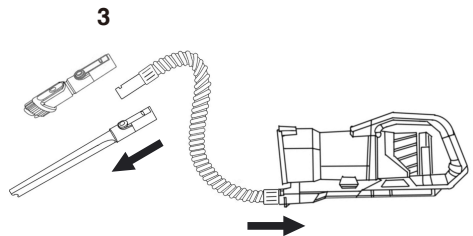



# How to use accessories

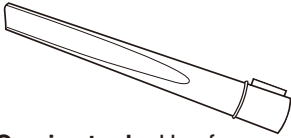

**Crevice tool** – Use for baseboard edges, sofas, detailing chairs, dryer vents and tight spaces.

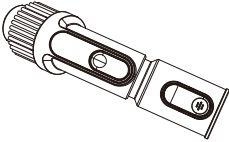

**2-in-1 Dusting brush + upholstery tool:** Use brush to vacuum blinds, vents or upholstered surfaces. Use felt portion to clean delicate surfaces. To switch between felt and brush portions, press thumb release and slide brush up or down.

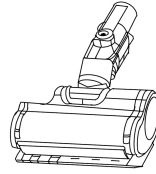

## **Motorized Pet & Stair Tool:**

Connect directly with canister to easily remove pet hair and debris from stairs and upholstery. Adjust angle of front nozzle to suit different surfaces. (Included with some models, can be purchased separately)

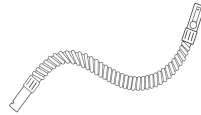

**Hose:** Connect accessories (crevice tool and 2-in-1 dusting brush + upholstery tool) for extended reach.



**CAUTION:** Make sure vacuum cleaner is turned off when attaching the Motorized pet & stair tool.

# How to maintain dust cup and filters



## CAUTION

Never operate vacuum cleaner without pre-motor and HEPA filters, filter screen and dust cup in proper position.

**WARNING:** Moving parts! Make sure vacuum cleaner is turned off and power cord is unplugged when performing any maintenance.

Empty dust cup when it reaches the Max Fill line and after every use

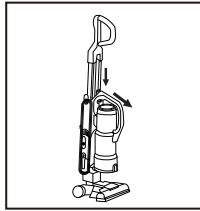

Press canister release button to remove the whole pod from the unit.

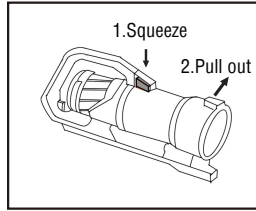

Squeeze the the purple dust cup release buttons and pull dust cup back and out.

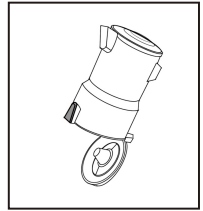

Hold dust cup over wastebasket and press lever to release bottom lid.

## Washable dust cup filters – Clean frequently



Remove the filter assembly upwards.

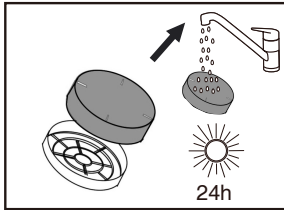

Lift out the pre-motor filter and shake of dust frequently. Every 3 months, rinse filter and dry **THOROUGHLY**.

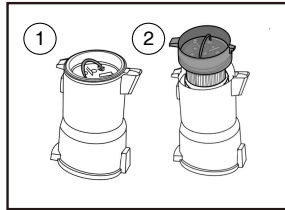

Pull up the metal ring, then remove the separator from the dust cup.

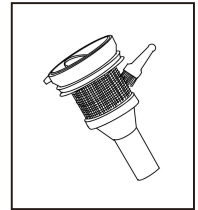

Clean the dust on the surface of the separation cone to keep the mesh open.

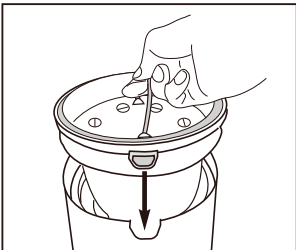

To put the separator back in place, align the front and back tabs on the separator with the corresponding slots on the dust cup and then carefully slide the separator back into the dust cup.

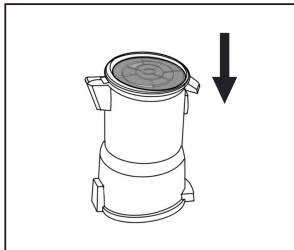

Reinstall pre-motor filter.

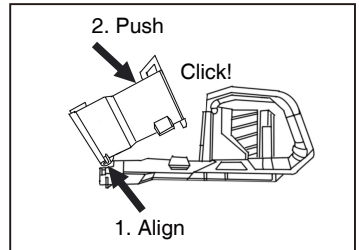

To place the dust cup back, angle it forward so the lower hook catches in the slot and then gently push it back towards the wand until you hear click indicating it is locked in place.



**WARNING:** Never operate vacuum cleaner without all filters, filter screen and dust cup in proper position.

# How to clean the dust separator

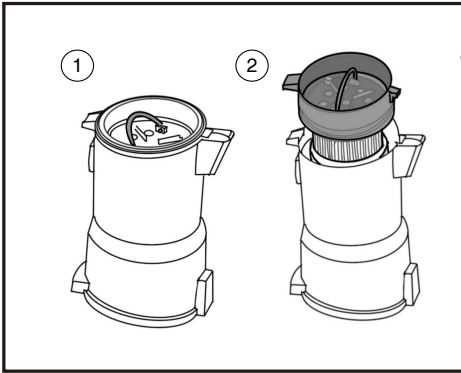

Pull up the metal ring, then remove the separator from the dust cup.

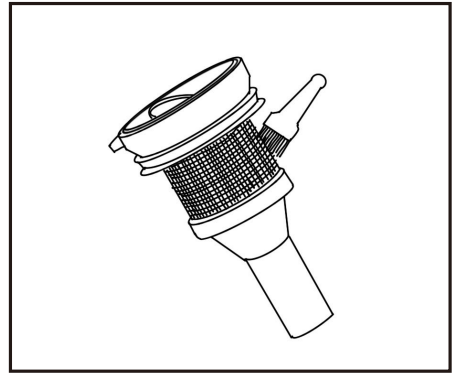

Clean the dust on the surface of the separator to prevent build-up from forming.

# How to clean HEPA Filter

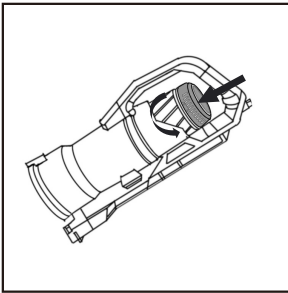

Turn the air outlet plate counterclockwise, and then remove the air outlet plate.

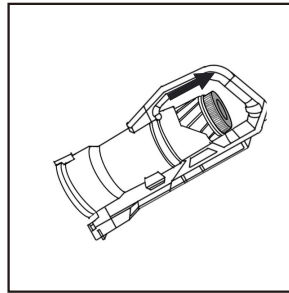

Remove the HEPA filter by pulling it up off the unit.

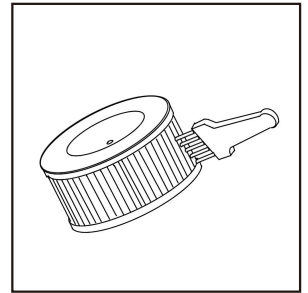

Gently tap the HEPA filter or use a brush to clean the dust on the HEPA surface.

# How to maintain the brushroll

To avoid unnecessary service calls, periodically check brushroll for debris.



## CAUTION

Make sure vacuum is turned off and power cord is unplugged.  
Warning: Do not attempt to remove belt. Call the Eureka Customer Service HELPLINE at 1-800-282-2886.

To ensure proper maintenance and effective cleaning performance, periodically clean the brushroll and brushroll ends by removing any remaining string, hair, carpet fibers, and other debris. Regularly check the brushroll and ends of brushroll for wear or damage.

Turn off vacuum and unplug from electrical outlet.

Turn vacuum upside down with brushroll facing upwards. Remove the brushroll lock by squeezing access tab and pulling it up off the vacuum (Fig. 1).

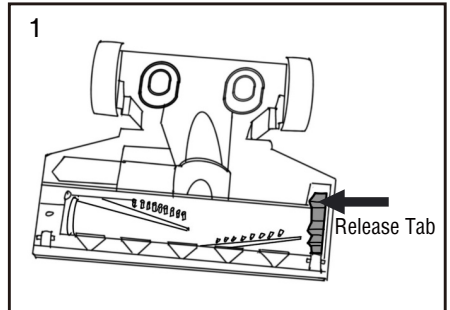

Remove brushroll by pulling tab end of roller up and then angle brushroll so it can be pulled out (Fig. 2).

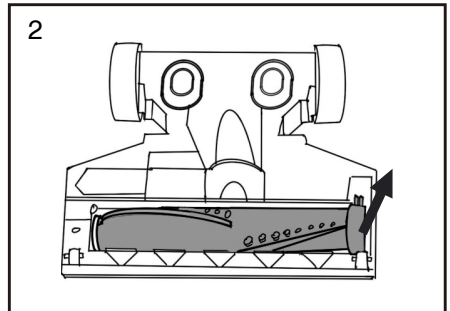

Clean off any debris from the brushroll. To reinsert the brushroll, angle it and align grooved end of brushroll with corresponding grooves on vacuum and push it back into place ensuring it is fully inserted in place (Fig. 3).

Then reinstall the brushroll lock tab until it clicks into place.

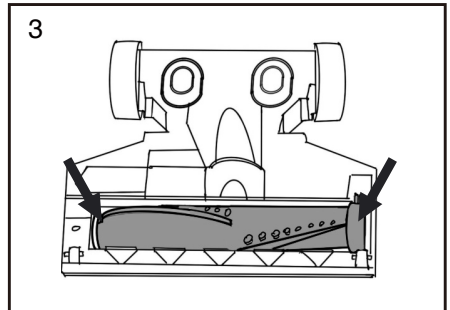

# How to clean a blockage



## CAUTION

Make sure vacuum is turned off and power cord is unplugged.

**WARNING:** Never operate vacuum cleaner without all filters, filter screen and dust cup in proper position.

**If the vacuum is not cleaning floors or if there is no suction at the end of the hose, check the air path for any blockage.**

- The cup release buttons are located on both sides at the bottom of the handle. Press and squeeze the purple buttons and pull dust cup out away from the machine (Fig. 1). See dust cup maintenance instructions on page 10.
- Empty the debris in the dust cup by holding the dust cup over the waste basket and press lever to release the bottom lid (Fig. 2).
- Check filters and filter screen. Remove any debris and shake off dust. See filter maintenance instructions on page 11.

**If there is still no suction, check for blockages in the floor nozzle**

- Remove the canister from the vacuum and step on the nozzle to lower handle and lay down the vacuum (Fig. 3).
- Check the hose for clogs (Fig. 4).
- Turn vacuum over on the floor, remove the brushroll and check air passageway and remove any obstructions (Fig. 5).

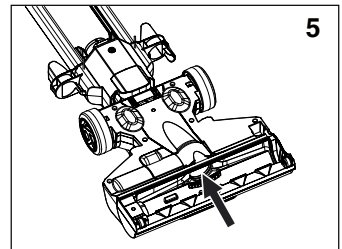
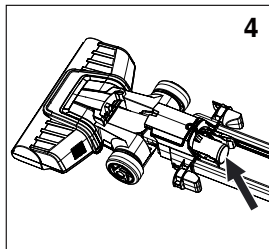
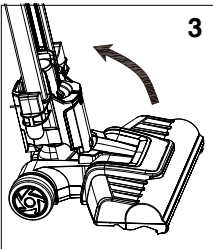
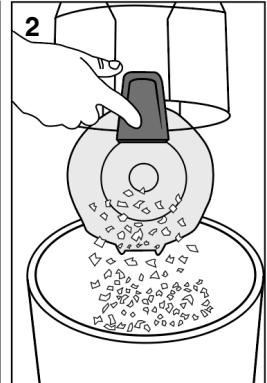
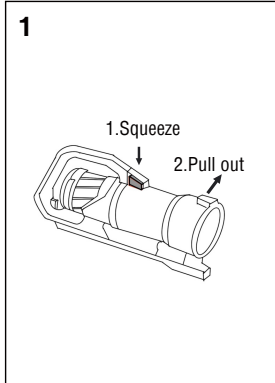

# Problem solving



Make sure vacuum is turned off and power cord is unplugged.

## NOTICE: Thermal cut-off

This vacuum cleaner has a special thermostat that protects the vacuum in case of motor overheating. **If the vacuum suddenly shuts off**, proceed as follows:

- 1) Turn the vacuum off and unplug the unit.
- 2) Check the vacuum for a possible source of overheating such as a full dust cup, blocked hose from the outlet or clogged filter. If any of these conditions are found, fix them and wait at least 30 minutes before attempting to use the vacuum.
- 3) After the 30 minute period, plug the vacuum back into the outlet and turn on the switch. If the vacuum still does not work, call the Eureka customer service helpline 1-800-282-2886.

## Trouble shooting

Below are some issues you may run into. If you don't see the issue below, please call Eureka customer service helpline 1-800-282-2886.

| Problem   | Solution  |
|---|---|
| Vacuum cleaner is not working                                   | Check if the power plug is securely inserted into the outlet<br>Check circuit breaker<br>If vacuum still does not run, see Thermal cut off on P14                     |
| Vacuum cleaner does not pick up any dirt or the suction is weak | Check if air inlet on floor nozzle or the hose is clogged and remove any blockages. See page 13.  |
|   | Check that brushroll and brushroll lock tab are correctly installed. See page 12.   |
|   | Clean and/or change filters regularly. See pages 10 and 11.   |
| Brushroll doesn't rotate or the mode light blinking             | Vacuum must be reclined for brushroll to spin. Step on floor nozzle and recline vacuum for vacuuming floors. See page 7.  |
|   | Remove brushroll, clear any debris and reinstall brushroll. See page 12.  |
| Canister cannot slide up/down                                   | When preparing to slide the canister upwards/downwards, press the "Slide up/down yellow trigger button FIRST and then slide the unit upwards/downwards, respectively. |

# The Eureka five-year limited warranty

Midea America Corp. ("Eureka"), subject to the terms and conditions herein, warrants this vacuum cleaner to be free from defects in material and workmanship for a term of five years from the date of original purchase when used in accordance with the Eureka operating and maintenance instructions and under normal household usage. This warranty is granted only to the original purchaser and members of immediate household, and is applicable only to original purchases from Eureka authorized resellers.

## What Eureka will do:

Eureka will, at its option, repair or replace a defective vacuum or vacuum part that is covered by this warranty. Repairs may be performed using new or refurbished parts that meet or exceed elects to replace the vacuum, the replacement may be a reconditioned unit. Depending on availability of products, Eureka reserves the right to provide you with a replacement product that is the same or similar, or substitute equivalent of the original product. As a matter of warranty policy, Eureka will not refund the consumer's purchase price.

## This warranty does not cover:

- Normal wear and tear of the vacuum and vacuum parts that require replacement under normal use light bulbs, brush-roll, bristles, impellers and cleaning.
- Damages or malfunctions resulting from: improper or unreasonable use or maintenance, abuse, negligence, failure to follow instructions contained in any written materials that accompany the product, deterioration by reason of excess moisture, corrosive atmosphere, lightning, power surges, connections to improper voltage supply, unauthorized alteration, or other external causes such as extremes in temperature or humidity, modifications, scratches or discoloration, accidents, misuse, or acts of God. This warranty also does not cover damage resulting from repair or attempted repair by anyone other than Eureka or an authorized Eureka Warranty Station. This warranty is not applicable to any product that has been altered or on which the serial number has been defaced, modified or removed. Altering, erasing, or forging any proof-of-purchase documents voids any applicable product warranty.

## Obtaining warranty service:

To obtain warranty service you must contact the Eureka Service Team, toll free, at 1-800-282-2886 or email [customerserviceusa@midea.com](mailto:customerserviceusa@midea.com), to discuss the warranty claim and procedures to be followed. All warranty claims must include submission of proof-of-purchase documentation. For additional information, you may also visit [www.eureka.com](http://www.eureka.com).

## Shipping charges:

You will be responsible for any initial shipping and insurance charges if the defective product(s) must be shipped for warranty service or warranty evaluation; however, Eureka or a Eureka Authorized Warranty Station will pay the return shipping charges if repairs are covered by the warranty. When returning parts for repair, you must include the model, type and serial number located on the rating plate. If any product submitted for warranty service is found to be ineligible, an estimate of repair cost will be furnished and the repair performed only if requested by the owner and upon receipt of payment or acceptable arrangements for payment.





## Further limitations and exclusions:

Any warranty that may be implied in connection with your purchase or use of the vacuum, including any warranty of Merchantability or any warranty of Fitness For A Particular Purpose is limited to the duration of this limited warranty. Some states do not allow limitations on how long an implied warranty lasts, so the above limitations may not apply to you.

Your relief for the breach of this warranty is limited to the relief expressly provided above. In no event shall the manufacturer be liable for any consequential or incidental damages you may incur in connection with your purchase or use of the vacuum. Some states do not allow the exclusion or limitation of incidental or consequential damages, so the above limitation or exclusion may not apply to you.

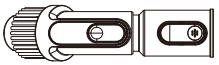
This warranty gives you specific legal rights. You may also have other rights, which may vary by state.

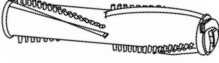
**Midea America Corp.**  
**300 Kimball Drive**  
**Parsippany, NJ 07054**  
**USA**

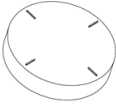
| Image   | Part name                              | Part # (Fits models) |
|---|--|----------------------|
|     | 2-in-1 Dusting Brush + Upholstery Tool | 12175000096187       |
|     | Crevice tool                           | 12175000096180       |
|    | Motorized Pet & Stair Tool             | 12175000096088       |
|     | Brushroll                              | 12175000A42392       |
|    | Brushroll Lock Tab                     | 12175000A42393       |
|   | Post-Motor HEPA filter                 | 12175000096089       |
|  | Pre-Motor foam filter                  | 12475000008289       |









**NEU800 series**

Upright vacuum cleaner; household type

# Owner's Guide

Thank you for purchasing your new Eureka vacuum!

## Important instructions

For easy assembly, please take a few moments to read this owner's guide.

If you have questions about your new vacuum, please contact our customer service **HELPLINE** at 1-800-282-2886. We're here to help!



[www.eureka.com](http://www.eureka.com)

# eureka